

DLP® Discovery™ Product Overview

Enabling New Emerging Products

The DLP® Digital Light Processing of Texas Instruments represents a proven technology of MEMS spatial light modulators also beyond standard projection and TV applications. The general purpose DLP® Discovery™ chipset is different from the DLP® standard projector hardware. DLP® Discovery™ gives direct control over the mirror array paving the way to new emerging applications. Spectroscopy, colour mixing, optical network switches, 3D scanners and direct imaging lithography for screen print and PCB production are some examples of successful DLP® products.

ViALUX is authorized Design House Partner reseller for the DLP® product line and supports customers around the world with standard components and customized solutions. ViALUX has long term experience in the Discovery™ platform since Discovery™1000 was released in 2001. The customers are supported from their first steps with **Starter Kits**, during the R&D phase using customized **ALP Controller** packages, **Optics and Light sources** up to the **Series Production** with DLP® chips and DMD formatter boards.

Starter Kits

Discovery™4100 is the recommended platform for all new customers and new product developments. It provides the highest performance available and a wide variety of DMD models.

Starter kits are provided for a convenient launch into the technology; they include

- Starter kit board with the DLP® chip
- Access to the DLP® KnowledgeBase with comprehensive technical information
- Explorer interface for experimental work

Discovery™4100 Starter Kits support the following DMD types:

	0.95" 1080p VIS	0.95" 1080p UV	0.7" XGA VIS	0.7" XGA UV
DMD array	1920x1080	1920x1080	1024x768	1024x768
mirror pitch	10.8 µm	10.8 µm	13.6 µm	13.6 µm



ALP Controller

The ALP-4.1 controller suite is a ViALUX software and firmware product designed for the Discovery™4100 platform; it supports both, the TI Starter Kits and the Series Production boards of ViALUX. The ALP principle of operation is based upon the reliable and fast USB2.0 transfer between PC and DLP® system using the full USB bandwidth. The ViALUX USB driver is fully certified UIF compliant and is available for both, 32bit and 64bit Microsoft® operating systems. Compressed data transfer is an option to increase the effective USB bandwidth.

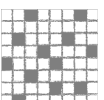

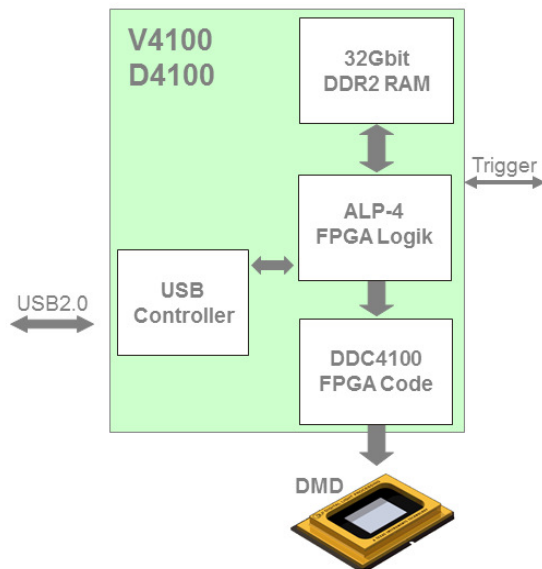

The 400 MHz FPGA logic is the core ALP component and brings the full DLP® performance into action.

There are two ALP models: The ALP-4.1 *basic* suite bypasses the SDRAM and the DMD array is directly addressed **line by line**.

The ALP-4.1 *high-speed* suite supports the display of both, binary pattern sequences and time average gray level patterns. Patterns are buffered in **32Gbit** SDRAM on-board memory and loaded into the mirror array from there.

The ALP application programming interface can be called from C++, VBasic, .NET, or LabView and Matlab projects. Other features are the precise triggering of the globally switching DMD array as well as the vertical scrolling of **patterns stored in the on-board memory**.

ALP-4.1 <i>basic</i>					
		0.7 XGA DMD		0.95 1080p DMD	
DMD area updated	Bit planes	Number of lines	Switching rate	Number of lines	Switching rate
full array	1 - binary	768	300 Hz	1080	100 Hz
single line	1 - binary	1	2 000 Hz	1	2 000 Hz
ALP-4.1 <i>high-speed</i>					
		0.7 XGA DMD		0.95 1080p DMD	
DMD area updated	Bit planes	Number of lines	Switching rate	Number of lines	Switching rate
full array	1 - binary	768	22 727 Hz	1080	10 638 Hz
full array	8 - gray	768	291 Hz	1080	255 Hz

Optics and Light Sources



For getting started with DLP® Discovery™ technology, ViALUX provides cost-efficient DLP® optics combined with high-power LED light sources. The LED-OM optical modules are available for all 0.7" XGA DMD chips of the Discovery™ platform. Red, green, blue, and white LEDs are available with a typical output of 225 lm in the standard white package. Even more powerful LED sources with up to 2000 lm or 10W optical output are supported and corresponding ViALUX digital HLD drivers are available.

Series production

The system configuration of the V4100 DLP® board is compatible to the Discovery™4100 Starter Kit boards. It includes the USB controller interfacing to the PC, one Virtex-5 FPGA for the ViALUX FPGA code (ALP 4 controller), one Virtex-5 FPGA for the Texas Instruments DDC4100 code (DMD controller), the SDRAM module for 32Gbit on-board memory, and the micro mirror device, a 0.7" XGA 2xLVDS DMD. Incoming data are buffered in the memory and the FPGA pair enables 24Gbit/s data rate from SDRAM to DMD.

