

## ViALUX DLP® Products at Photonics West 2011

DLP® micro-mirror technology of Texas Instruments has been presented at the Photonics West Exhibition in San Francisco this year. ViALUX was invited as DLP® Design House Partner to show latest developments around the DLP® Discovery™ 4100 high-performance DLP® platform. The versatile ViALUX Production Board V4100 with ALP-4 Controller Suite has received very positive feedback and led to new projects and products in the fields of selective curing for rapid prototyping, direct imaging lithography, hyper-spectral imaging, wave front sensing and compressed image sensing. In addition, the ALP-4 controlled high-power 388 nm UV LED paves the way to integrated, all-solid-state system solutions. More new ideas have been born in customer meetings and will be followed-up during upcoming months.



### DLP® Production Board V4100: fast, flexible, proven

Designed as an OEM component for use in customer products, the V4100 DLP® production board of ViALUX proved reliable high performance operation in production systems and is working successfully in the field. Running at 400 MHz clock rate, the full speed of the Discovery™ 4100 chipset is made available for customers. Advanced software and FPGA design allow for global DMD array switching rate of 22 727 binary XGA patterns per second for up to 43 690 images stored in the 32 Gbit on-board memory. Lossless compression yields 1500 XGA patterns per second upload rate from PC via USB2.0. Foot print is kept as small as possible and the flex-rigid PCB design gives the customer freedom in device design. As an example, the picture shows a compact multi-color LED based DLP® system for use in advanced high-speed pattern projection applications; the V4100 production board is visible in the lower right corner.

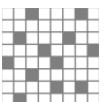

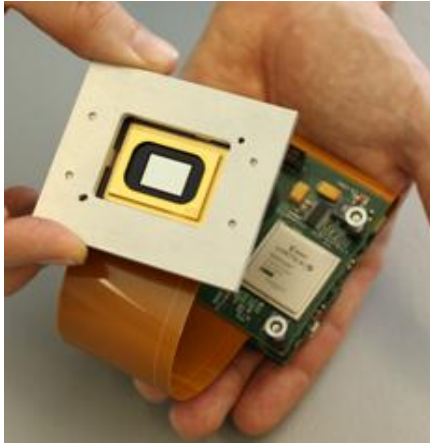

## Digital LED Controller: fully integrated in ALP-4

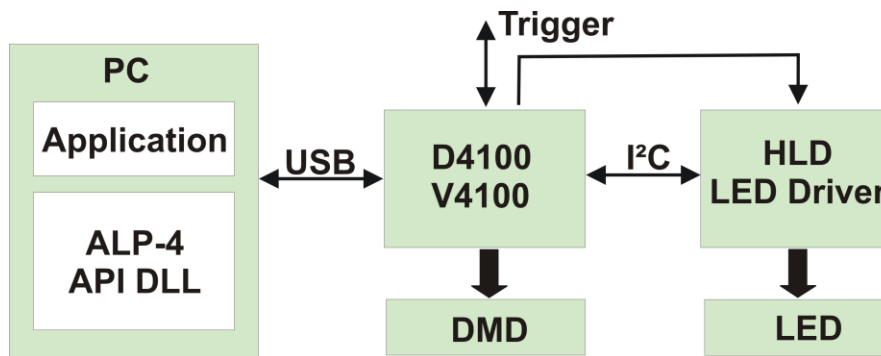

Designed for up to 24 A current supply, the ViALUX HLD driver supports DLP® Discovery™4100 applications in combination with the most recent high-power LED light sources on the market. Now, this digital LED driver is seamlessly integrated in the ALP-4 Controller Suite API and can be software addressed from the PC via USB. Customers are able to

- Set the LED current
- Read the actual LED current
- Read the LED temperature sensor of Luminus PT120/121 LEDs
- Get the LED junction temperature of Luminus PT120/121 LEDs

The user may connect further I<sup>2</sup>C based devices by using the general I<sup>2</sup>C interface provided in the ALP-4 API.

